

1 Ch LED Booster/Dimmer

Datasheet
Control Gear

LED ballast usable as PWM Booster
or Dimmer with 0-10V control input

Art. Nr. 86459838

1 Ch LED Booster/Dimmer Control Gear

Overview

- 1 channel LED dimmer
- suitable for constant voltage LED-modules
- control signals: PWM (50Hz-1kHz), 100kOhm potentiometer, 0-10V voltage signal (active and passive)
- logarithmic dimming curve
- Analog input: connection of a 100kOhm potentiometer or a 0-10V control device (active or passive), the 0-10V input signal is transformed in a corresponding PWM output signal
- PWM control signal: suitable for operation with a LED-dimmer with common plus connector
- Supply voltage of 12V to 48V DC, d
- maximum current: 16A
- suitable for remote ceiling

Spezifikation, Characteristics

type	1Ch LED Booster Dimmer
article number	86459838
electrical data:	
supply	12VDC-48VDC
maximum input current	16A
control input	PWM (50Hz-1kHz) 100kOhm potentiometer 0-10V active/passive
technical data:	
storing and transportation temperature	-20°C to +75°C
operating ambient temperature	-20°C to +60°C
expected lifetime (at Tc<=75°C)	>50000h
protection class	IP20
max. connecting wire crosssection	2.5 mm ²
mounting	remote ceiling
dimension (LxWxH)	120mm x 30mm x22mm

RECOMMENDATION: Care should be taken on keeping cable lengths between DC power supply and dimmer as well as between dimmer and luminaires (Led-Strings) as short as possible. This kind of installation will minimize the influence of voltage drops.

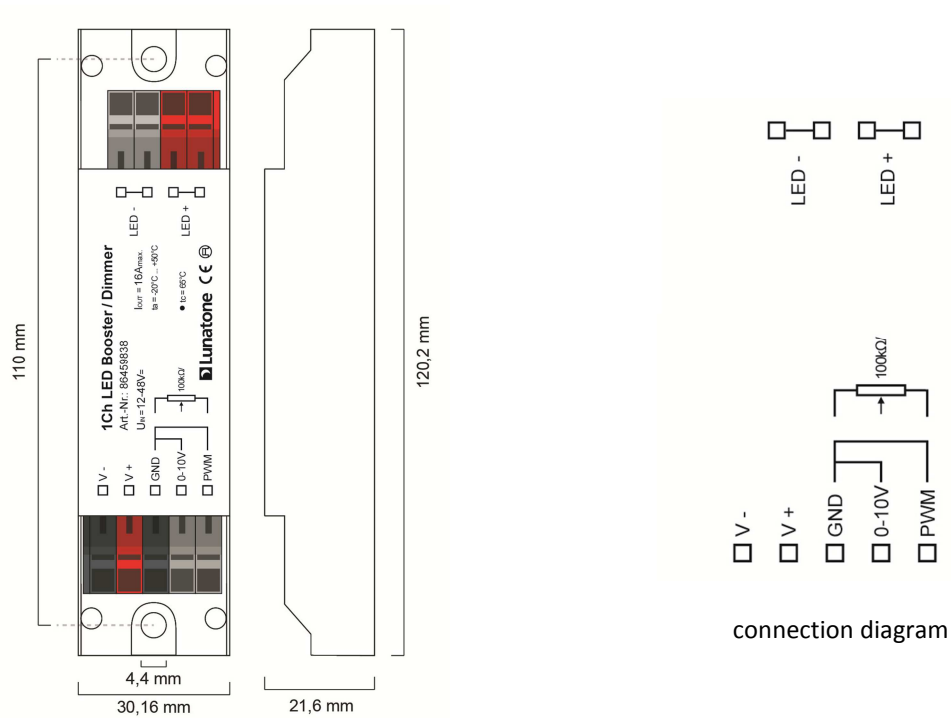

geometry

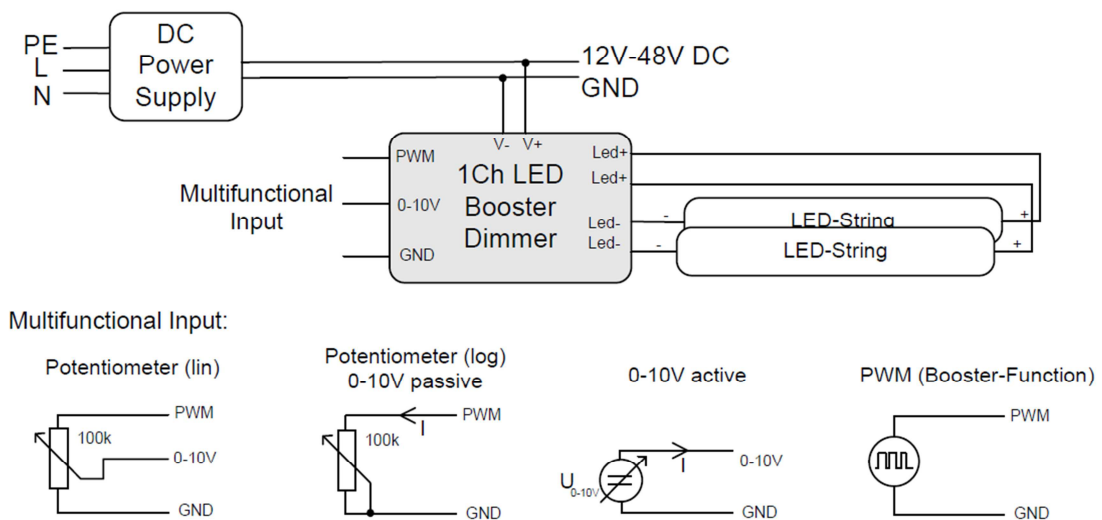

typical structure & control input configurations

Application: PWM-Booster for RGB-CV dimmer (common plus connector)

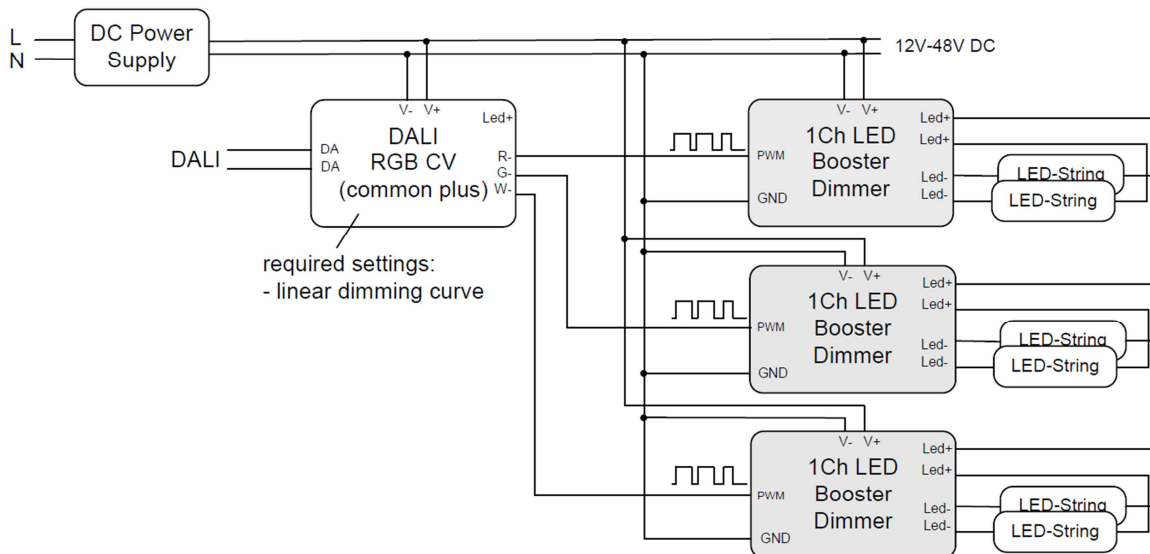

Application: PWM-Booster with DALI PWM module

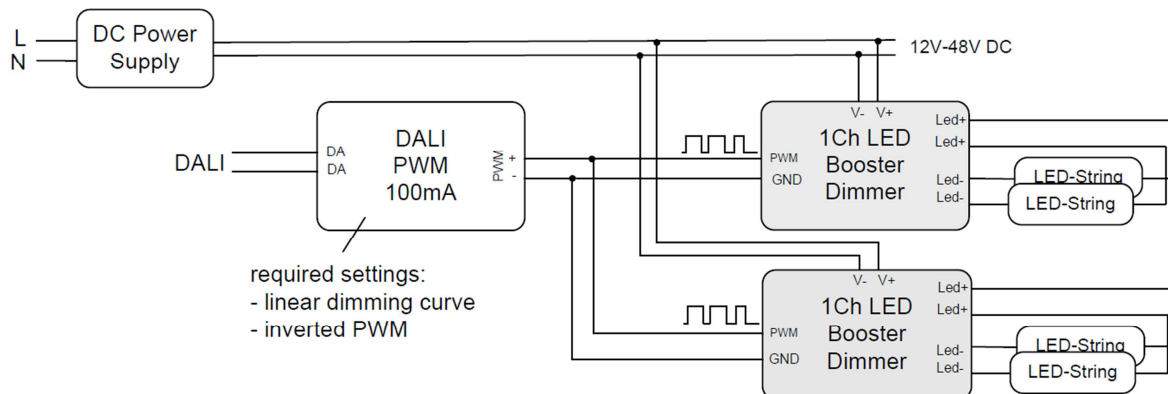

command sequence for switching dimming curve of a DT6 LED-dimmer to linear:

Type	Hex Data	Address	Command
DALI16 Special	C106	*	ENABLE DEVICE TYPE 6
DALI16 AppExt	D6 03EE	A1	QUERY DIMMING CURVE
DALI8 Answer	00		= 0 (0x00)
DALI16 Special	A301	*	DATA TRANSFER REGISTER= 1 (0x01)
DALI16 Special	C106	*	ENABLE DEVICE TYPE 6
DALI16 AppExt	D6 03E3	A1	SELECT DIMMING CURVE
DALI16 AppExt	D6 03E3	A1	SELECT DIMMING CURVE
DALI16 Special	C106	*	ENABLE DEVICE TYPE 6
DALI16 AppExt	D6 03EE	A1	QUERY DIMMING CURVE
DALI8 Answer	01		= 1 (0x01)

Purchase Order Information

Art.Nr. 89459838: 1Ch LED Booster/Dimmer
LED dimmer for the control of CV LED
modules, multifunctional 0-10V input, PWM-
Booster function, 12V-48VDC, 16A max.

Additional Information and Equipment

DALI-Cockpit – free configuration tool from
Lunatone for DALI systems

http://lunatone.at/en/downloads/Lunatone_DALI-Cockpit.zip

Lunatone DALI products

<http://www.lunatone.at/en/>

Lunatone datasheets and manuals

<http://lunatone.at/en/downloads/>

Contact

Technical Support: support@lunatone.com

Requests: sales@lunatone.com

www.lunatone.com



Disclaimer

Subject to change. Information provided without guarantee.
The datasheet refers to the current delivery.

The compatibility with other devices must be tested in advance
to the installation.