

DALI-2 IoT

Datasheet

DALI-LAN Interface



Central control module and
DALI-LAN Interface

Art.Nr. 89453886
GTIN: 9010342013607

DALI IoT Central Control Device & Interface

Overview

- Interface module to connect a DALI network and a LAN network
- IoT (LAN) interface to DALI: addressing, status queries, monitoring, etc. of DALI ballasts
- RESTful API endpoints and WebSocket with JSON syntax, encrypted (optionally unencrypted) for custom integrations
- Connect and control separate DALI circuits via several DALI gateways via LAN
- Integration with local network-based third-party systems: Selected IoT platforms for the consumer market (e.g. Alexa, IFTTT, etc.)
- DIN rail mounting (1TE)
- Supply 24VDC (e.g. : with 24V / 300mA Art.Nr. 24166012-24HS)



Specification, Characteristics

type	DALI-2 IoT
article number	89453886
GTIN	9010342013607
electrical data:	
power supply	24VDC
typ. current consumption	90 mA
Ethernet	1xEthernet 10/100Base-T, electrically isolated, isolation voltage 1500VAC, RJ45-connector
DALI	1 x DALI, electrically isolated
technical data:	
storage and transportation temperature	-20°C ... +75°C
operational ambient temperature	-20°C ... +60°C
protection class	IP20
max. connecting wire cross section	2,5 mm ²
mounting	DIN rail
dimensions	98 x 23 x 56 mm

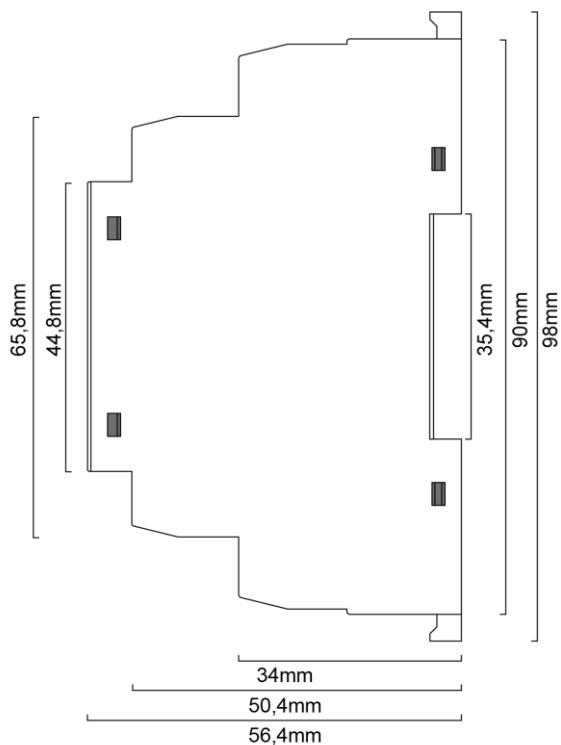

dimensions

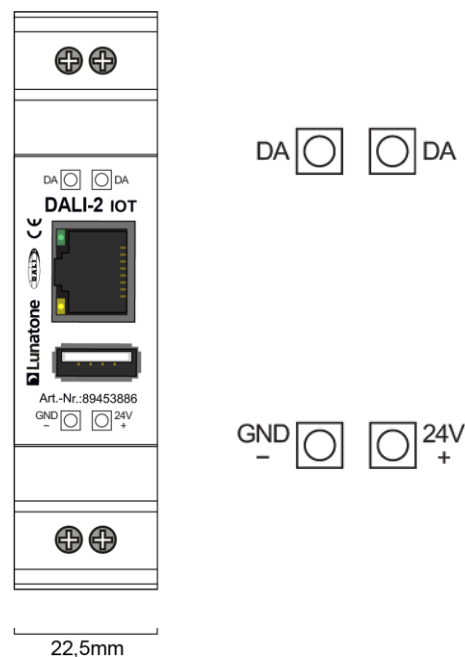

connection plan

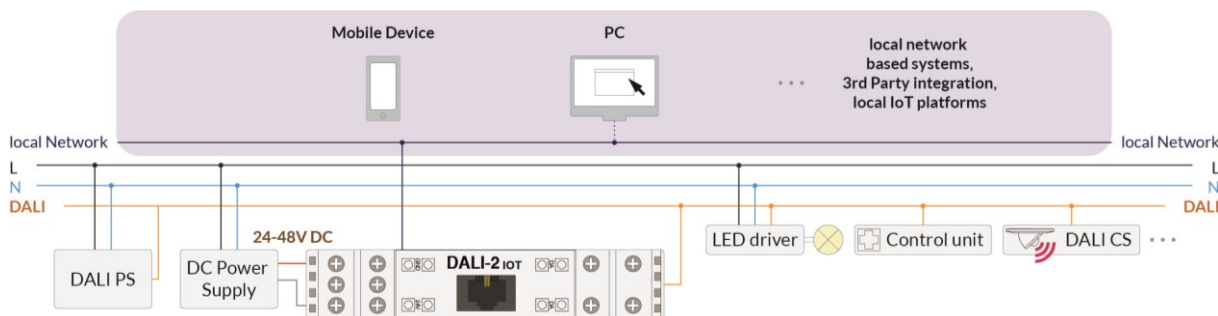

typical application

Installation

- supply voltage 24VDC - the DALI-2 IoT device requires a 24 V supply, which is connected to the terminals provided for this purpose (suitable power supply unit: PS 24V, 300mA, article nr.: 24166012-24HS).
- The DALI-2 IoT is connected directly to the DALI bus. The supply of the DALI circuit must be ensured by a suitable DALI bus power supply (e.g. DALI PS article nr.: 24033444).
- The connection to the DALI terminals can be made regardless of polarity. The bus

input is protected against overvoltage (mains voltage).

- The wiring should be carried out as a permanent installation in a dry and clean environment.
- Installation may only be carried out in a voltage-free state of the system and by qualified specialists.
- National regulations for setting up electrical systems must be followed.
- The DALI wiring can be realized with standard low-voltage installation material. No special cables are required.
- Only 1 wire may be connected to each terminal. When using double wire end ferrules, the connection capacity of the terminal must be considered.

 **Attention:** The DALI-signal is not classified as SELV circuit (Safety Extra Low Voltage). Therefore, the installation regulations for low voltage apply.

 The voltage drop on the DALI line must not exceed 2V at maximum length (300m) and maximum bus load (250mA).

Functionality

The DALI-2 IoT Gateway is an interface for connecting the DALI system with smart devices to the Internet of Things (IoT) via the local network.

Thereby, a simple implementation of an intelligent system is possible with the DALI-2 IoT gateway. Devices can be controlled and monitored via smartphones, PCs, etc.

Basic services and API documentation are available to enable power monitoring, remote support and much more

To use the API documentation, it is necessary to know the IP address of the DALI-2 IoT device. This can be determined using a "Discovery" protocol provided by the DALI-2 IoT device.

For more information see the DALI-2 IoT-API manual: [DALI IOT API documentation](#)

Purchase Order Information

Art.Nr. 89453886: DALI-2 IoT, DALI – LAN interface.

Accessories:

Art. Nr.: 24166012-24HS, 24VDC/300mA power supply, DIN rail, 1TE

Additional Information and Equipment

DALI-2 IoT API manual

https://www.lunatone.com/wp-content/uploads/2021/08/89453886_DALI2_IOT_API_Dokumentation_EN_M0023.pdf

Lunatone DALI products

www.lunatone.com/en/

Lunatone datasheets and manuals

www.lunatone.com/en/downloads-a-z/

Contact

Technical Support: support@lunatone.com

Requests: sales@lunatone.com

www.lunatone.com



Disclaimer

Subject to change. Information provided without guarantee.
The datasheet refers to the current delivery.

The compatibility with other devices must be tested in advance to the installation.