

DALI-2 BT5 Room Controller KNX

Datasheet

Bluetooth 5.0 Interface
with KNX input



DALI-2 Bluetooth Interface
for commissioning,
configuration and control
of DALI systems using
the smartphone app
DALI Cockpit Mobile
with an additional KNX input

Art.Nr. 87454427-KX

DALI-2 BT5 Room Controller KNX

Overview

- DALI-Bluetooth Interface
- Unit for commissioning, configuration and control of a DALI system via Bluetooth using the Lunatone smartphone application DALI Cockpit Mobile
- KNX TP interface
- Product database for ETS5/6 (8 gates)
- Switching and dimming of DALI gears via KNX
- DALI scene control using KNX scenes
- Status objects for KNX
- Output with DALI power supply (200mA) for the supply of up to 64 DALI devices
- Enables simple room solutions
- Test button for functional testing
- Smartphone application for easy configuration of Lunatone devices. (List of supported devices see section "Function" on page 6.
- The interface description - LUBA protocol is available for the implementation of your own user interfaces (see section "Additional information" on page 7).



Specification, Characteristics

| type | DALI-2 BT5 Room Controller KNX |
|---------------------------|--------------------------------|
| article number | 87454427-KX |
| input: L, N | |
| input type | supply, mains- voltage |
| marking terminals | L, N |
| input voltage range | 100Vac ... 240Vac |
| max. input supply current | 40mA (@120Vac), 20mA (@240Vac) |
| input supply frequency | 50Hz / 60Hz |
| max. power consumption | 5,3W |
| startup time | 250ms |
| input: KNX | |
| input type | KNX/TP |
| marking terminals | KNX- / KNX+ |
| input voltage range | DC 21 ... 32V SELV |
| max. input supply current | 6mA |
| max. power consumption | 150mW |

output: DA+, DA-

| | |
|--------------------------------|-------------------|
| output type | DALI supply |
| marking terminals | DA+, DA- |
| voltage range | 12Vdc ... 20,5Vdc |
| guaranteed DALI supply current | 180mA |
| max. DALI supply current | 250mA |
| open circuit proof | yes |
| short circuit proof | yes |

insulation data:

| | |
|---|----------------------|
| impulse voltage category | II |
| pollution degree | 2 |
| rated insulation voltage | 250V |
| insulation DALI (DA+, DA-) / supply (L, N) | reinforced isolation |
| insulation test voltage DALI-output/mains | 3000Vac |

environmental conditions:

| | |
|--|-----------------|
| storing and transportation temperature | -20°C ... +75°C |
| operational ambient temperature | -10°C ... +55°C |
| rel. humidity, none condensing | 15% ... 90% |

general data:

| | |
|-----------------------------|---|
| dimensions (l x w x h) | 159mm x 42mm x 22mm |
| mounting | remote ceiling integration in class II devices |
| rated max. temperature tc | 70°C |
| expected life time @tc | 50.000 h |
| protection class | II in intended use |
| protection degree housing | IP40 |
| protection degree terminals | IP20 |

terminals:

| | |
|----------------------------------|--|
| connection type | spring terminal connector |
| wire size solid core | 0,5 ... 1,5 mm ² (AWG20 ... AWG16) |
| wire size fine wired | 0,5 ... 1,5 mm ² (AWG20 ... AWG16) |
| wire size using wire end ferrule | 0,25 ... 1 mm ² |
| stripping length | 8,5 ... 9,5mm / 0,33 ... 0,37inch |
| locking torque | - |
| release of wire | push button |

standard:

| | |
|----------|------------------------------------|
| DALI | EN 62386-101 |
| EMV | EN 61547 EN 50015 / IEC CISPR15 |
| Safety | EN 61347-2-11 EN 61347-1 |
| markings | CE |

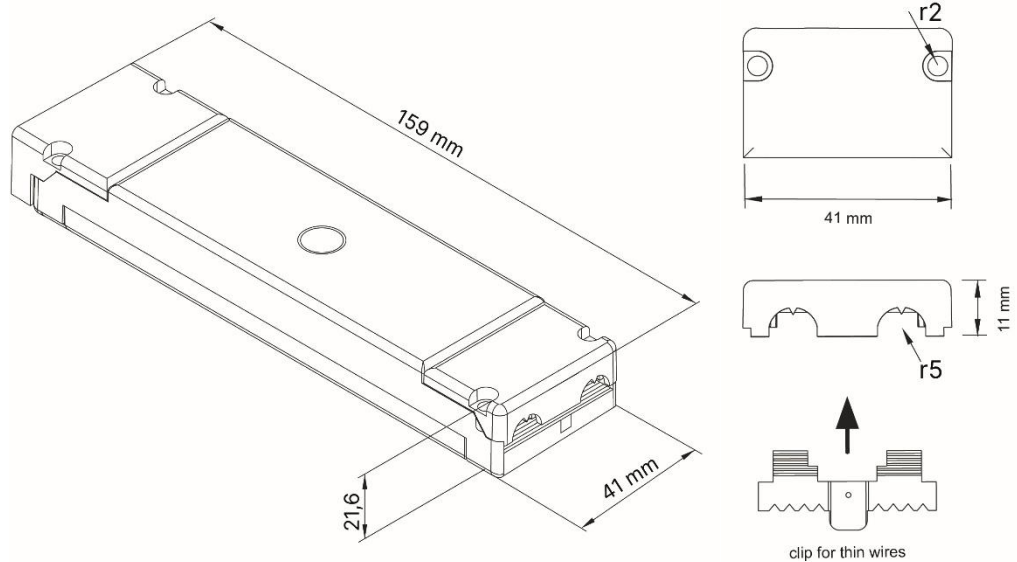
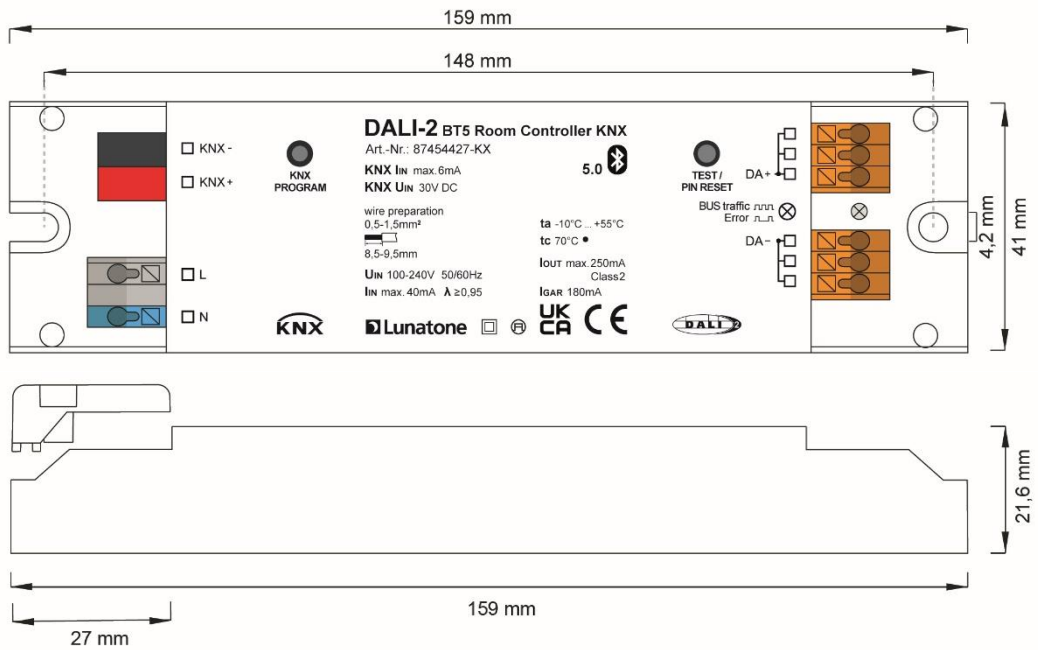

dimensions



terminals

Installation

- The Room Controller KNX is intended for remote installation in the ceiling or in an enclosure, ensure proper cable relief for installation in protection class II devices.
- The wiring should be carried out as a permanent installation in a dry and clean environment.
- Installation may only be carried out in a voltage-free state of the system and by qualified specialists.
- National regulations for setting up electrical systems must be followed.
- connect power supply terminals L and N to mains voltage.
- the polarity of the output voltage is marked on the housing (DA+, DA-)
- The DALI-line may be installed within the same cable or as single conductors within the same tube as mains supply.
- The DALI-line must not be connected to the mains or extra low voltage systems.

- The DALI wiring can be realised with standard low-voltage installation material. No special cables are required.
- Wiring topology of the DALI-line: Line, Tree, Star.
- Wiring check by pressing the test button: the LED is flashing and all luminaires connected to the DALI system will be controlled by a test sequence (on, off, dimming). To quit the test mode, press the test button again.



Attention: The DALI-signal is not classified as SELV circuit. Therefore, the standards for installation in low voltage system apply.



The voltage drop on the DALI-line shall not exceed 2V.



Attention: an improper DALI power supply can cause damage on DALI devices!

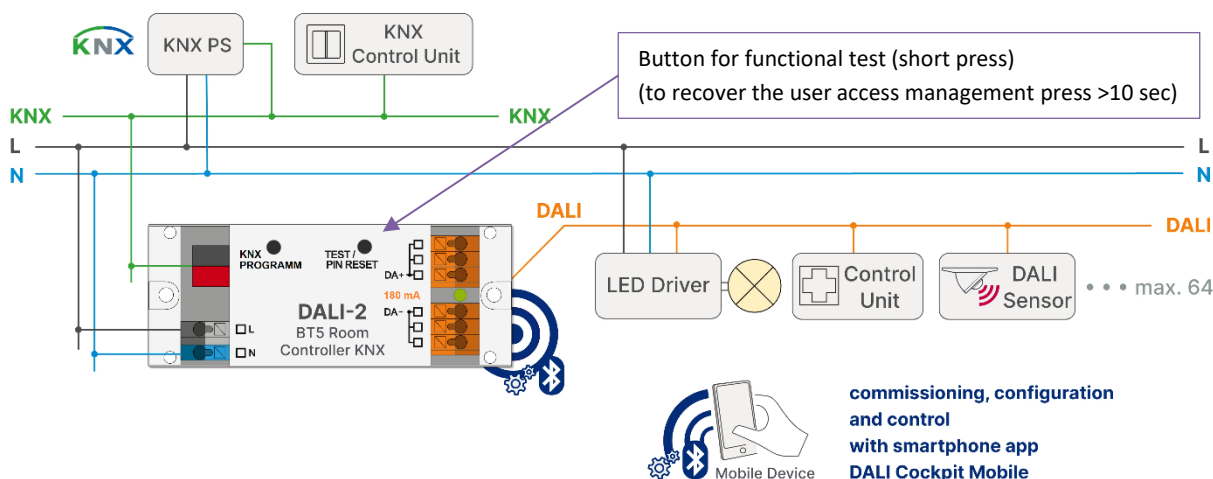

Fig. 1 Installation Room Controller KNX – typical Application

Commissioning

- After installation, the DALI-Room Controller KNX is ready for use.
- It must be ensured that the maximum power consumption on the DALI circuit does not exceed the guaranteed output current (200mA) of the DALI Room Controller KNX at any time.
- The DALI Room Controller KNX can be connected to the smartphone application DALI Cockpit Mobile to control and configure the devices on the DALI bus.
- The connection of a smartphone with the DALI Room Controller KNX is possible via Bluetooth.
- Pressing the test / PIN reset button for > 10 seconds (LED on the device lights up), enables recovery of the user access management in the smartphone application (for instructions see the [app manual](#)).
- Status-LED:
 - flashing 5Hz, 50% on: test mode
 - flashing 2Hz, 5% on : error (Overload / short circuit)
 - flashing 2Hz, 90% on: activity

Function

The DALI Room Controller KNX serves as an interface between Bluetooth and DALI. Simplified, the packets received via Bluetooth are converted into corresponding DALI commands and vice versa. This means that devices connected to the DALI bus can be operated and configured via the Bluetooth interface.

The Room Controller KNX can be connected to a KNX system for control of DALI gears via KNX (switching, scenes). Up to 8 gate

functionalities can be implemented using the product database (ETS5/6). Each gate supports all DALI addressing types. Various KNX status objects are available for visualization. Setting up the KNX interface is described in the following section

The Room Controller KNX also provides the power supply (200mA) for the DALI bus. Therefore, simple room solutions can be easily implemented with the DALI Room Controller KNX.

The Lunatone smartphone [application DALI-Cockpit Mobile](#) offers a clear and simple interface for controlling and configuring Lunatone devices on the DALI bus. The following devices are currently supported by the smartphone application:

Operating devices:

- DALI Dimmer (all 230V and 12-48V operating devices by Lunatone)
- DALI Jalousie Module (Art. Nr.: 86458676)
- DALI Relay Module (Art. Nr.: 86458675, Art. Nr.: 86458629)

Sensors:

- DALI-2 CS (Art. Nr.: 86458670, Art. Nr.: 86457244, Art. Nr.: 88793325)

Control / Input Devices:

- DALI-2 Touchpanel (Art. Nr.: 24035410)
- DALI-2 Switch Cross (Art. Nr.: 86459793-*Farbcode-2*)
- DALI-2 MC (Art. Nr.: 86459532-2)
- DALI-2 MC4L (Art. Nr.: 86458507-4L-2)
- DALI Rotary (Art. Nr.: 86459822, Art. Nr.: 86459822-TW, Art. Nr.: 86459822-RGB, Art. Nr.: 86459822-RGBW)

Further control devices (max 1pcs each per Room Controller):

- DALI CDC (Art. Nr.: 89453853)
- DALI RTC (Art. Nr.: 86459531)
- DALI-2 Sequencer (Art. Nr.: 89453371)

Communication between the smartphone app and the DALI Room Controller KNX is based on the proprietary [Lunatone Universal Building and Automation Protocol \(LUBA-Protocol\)](#).

The protocol documentation is available, see also section “Additional Information and Equipment” for the download link.

Set up - KNX

1. Start the ETS5/6 and load the Gateway's product database.
2. Assign the KNX address to the Gateway:
→ When requested, press the “Prog. button” on the device housing.
If the address has been assigned successfully, the red LED will turn off.
3. Optional: apply configurations to the DALI system with the Lunatone DALI Cockpit Mobile App.
4. Configuration of the required gates in the ETS (function, DALI address).
5. Load the settings made in the ETS into the Gateway.

ETS (KNX configuration Software)

An ETS (version ETS 5/6) product database for the gateway is available.

Download link for ETS product database:
<https://www.lunatone.com/en/downloads-a-z/>

All necessary settings for the KNX system can be made using the ETS. For larger projects, it can be useful to rename the gates and enter the used DALI addresses - this can increase clarity in the product database. See Fig.3 below.

ETS - GATES

In the ETS, the following gate types are available for each of the 8 gates:

- Switch& Dim Gate,
- Scene Gate

See also Fig. 4., the gate specific settings are described on the pages 8-10.

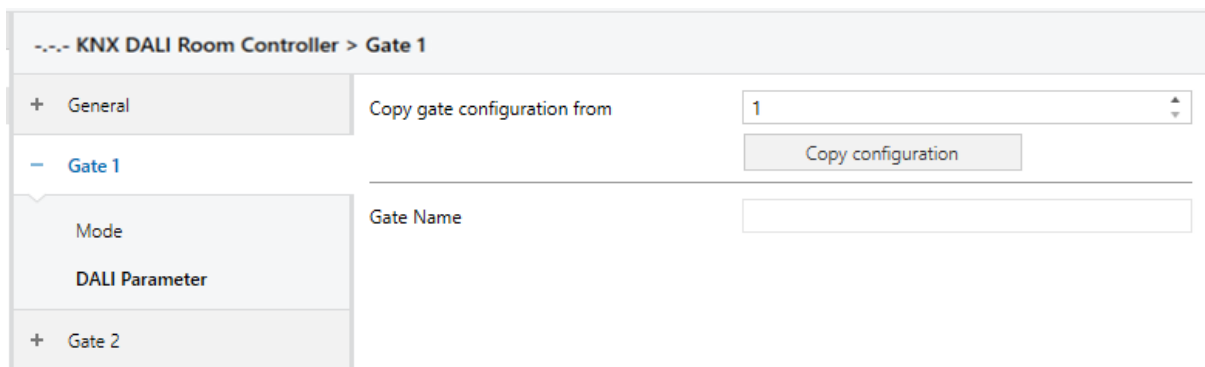

Fig.3 Gate Settings ETS

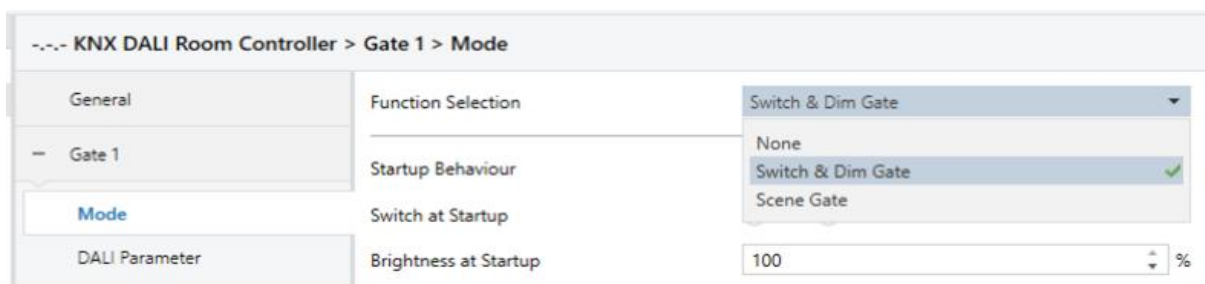

Fig.4 Gate Settings ETS: Gate Type Selection

Switch&Dim Gates

The gate type Switch&Dim offers the possibility to switch and dim lights.

Start-up (reset) behaviour

In the tab “Mode” two possible start-up behaviours can be selected:

- Recall of a predefined values: values can be defined with the ETS, at start-up the status communication objects are automatically sent.

- no action
see also Fig. 5

DALI Parameter

In the tab: "DALI parameters" the following DALI parameters can be set:

- Addressing Mode: all DALI address types are supported: single address, groups, and Broadcast.
- Behaviour when switching on (Switch On),
- Behaviour when switching off (Switch Off),
- The minimum attainable level when dimming (Minimum dim level)
- the dimming behaviour: linear or logarithmic (dimming value calculation type).

see also Fig.6.

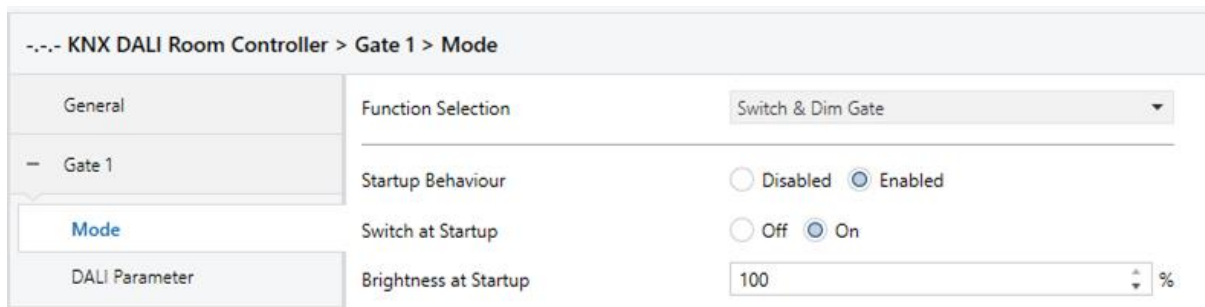

Fig.5 Gate Settings ETS: Tab „Mode“ Switch & Dim Gate



Abb.6 Gate Settings ETS: Tab „DALI Parameter“ Switch & Dim Gate

Scene Gates

Each of the 8 gates can be configured as a scene gate. 4 different settings can be selected: scene number (17.0001), scene AB (1.002), scene steps (1.007) and KNX scene to several DALI scenes (17.001).

- **Scene Number (17.001)**

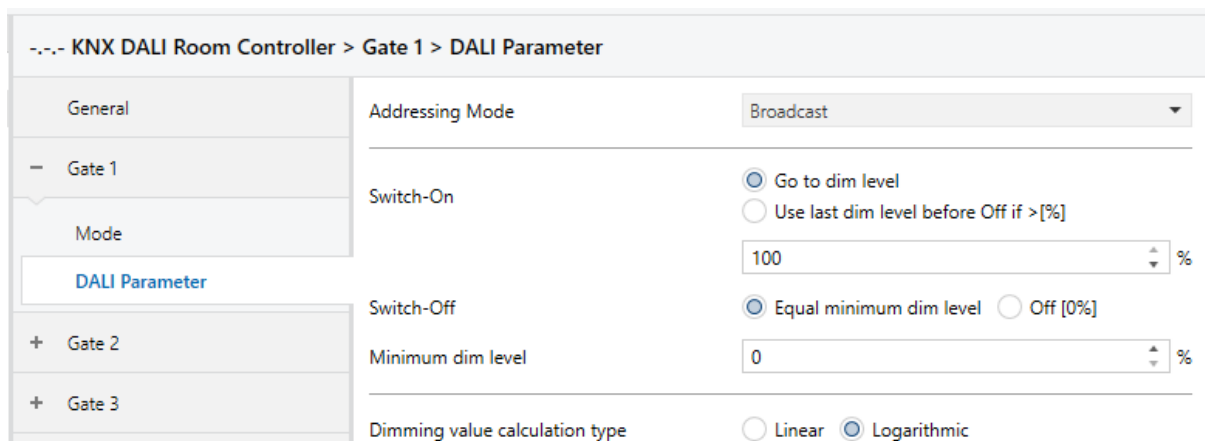
see also Fig. 7

The data point type 17.001 (Scene Number) is used as communication object. Two KNX scenes can be converted into two DALI scenes. The DALI addressing type: broadcast, group or short address can be selected.

The re-start behaviour can be set: if enabled, the device sends the corresponding assigned DALI scene depending on the setting.

Fig.7. Gate Settings ETS Scene Gate Type: Scene Number (17.001)

- **Scene AB(1.022)**

see also Fig. 8

The data point type 1.002 (Scene A/B) is used as communication object. KNX Scene A and B can each be assigned to a DALI scene. The DALI addressing type: broadcast, group or short address can be selected.

The re-start behaviour can be set: if enabled, the device sends the corresponding assigned DALI scene depending on the setting.

Fig.8. Gate Settings ETS Scene Gate Type: Scene AB (1.022)

- **Scene Steps (1.007)**

see also Fig. 9

The data point type 1.007 (step) is used as communication object. A DALI scene table can be defined in the gate, specifying which DALI scenes are recalled. The increase and decrease information determines in which direction the table is traversed. Increasing means that the next higher DALI scene is activated, while decreasing activates the next smaller scene. The table is run through endlessly, in case of an overflow a jump is made to the smallest or largest defined scene, depending on the direction.

The re-start behaviour can be set: if enabled, the device sends the first active scene (lowest number) in the table. The DALI addressing type: broadcast, group or short address can be selected.

Function Selection: Scene Gate

Type of Group Object: Scene Steps (1.007)

Startup Behaviour: Disabled Enabled

Send first used scene of sequence on startup

Addressing Mode: Broadcast

i Select the DALI scenes for the sequence

| | | |
|--------------|--------------------------------------|---------------------------------|
| DALI Scene 0 | <input checked="" type="radio"/> Use | <input type="radio"/> Don't use |
| DALI Scene 1 | <input checked="" type="radio"/> Use | <input type="radio"/> Don't use |
| DALI Scene 2 | <input checked="" type="radio"/> Use | <input type="radio"/> Don't use |
| DALI Scene 3 | <input checked="" type="radio"/> Use | <input type="radio"/> Don't use |
| DALI Scene 4 | <input checked="" type="radio"/> Use | <input type="radio"/> Don't use |
| DALI Scene 5 | <input checked="" type="radio"/> Use | <input type="radio"/> Don't use |

Fig.9. Gate Settings ETS Scene Gate Type: Scene Steps (1.007)

- **KNX Scene to multiple DALI Scene (17.001)**

see also Fig. 10

A KNX scene calls up to four DALI scenes. The addressing type (group, short address) can be specified for each DALI scene. The data point type 17.001 (Scene Number) is used as the communication object.

KNX Scene: KNX Scene 1

Addressing Mode: Group Address Short Address

| | | |
|-------------|---------|--------------|
| Scene (I) | Group 0 | DALI Scene 0 |
| Scene (II) | Group 1 | DALI Scene 1 |
| Scene (III) | Group 2 | DALI Scene 2 |
| Scene (IV) | Group 3 | DALI Scene 3 |

Fig.10. Gate Settings ETS Scene Gate Type: KNX Scene to multiple DALI Scene

Purchase Information

Art.Nr. 87454427-KX: DALI Room Controller KNX, Bluetooth – DALI interface with integrated bus power supply, remote ceiling

Additional Information and Equipment

Lunatone datasheets, manuals and software
<http://www.lunatone.com/downloads-a-z/>

Lunatone DALI products
<http://www.lunatone.com>

Lunatone Universal Building and Automation Protocol (LUBA) - Documentation
https://www.lunatone.com/wp-content/uploads/2021/04/LUBA_Protocol_EN.pdf

Smartphone Application “DALI Cockpit Mobile” Manual:
https://www.lunatone.com/wp-content/uploads/2020/11/87454427_DALI-2_BT5-Room-Controller_APP_EN_M0020.pdf



DALI-Cockpit/Mobile App -
Google Store Download
<https://play.google.com/store/apps/developer?id=Lunatone+Industrielle+Elektronik+GmbH&hl=de>



DALI-Cockpit/Mobile App -
Appstore Download
<https://apps.apple.com/de/developer/lunatone/id624497126>

Contact

Technical Support: support@lunatone.com

Requests: sales@lunatone.com

www.lunatone.com



Disclaimer

Subject to change. Information provided without guarantee.
The datasheet refers to the current delivery.

The function in installations with other devices must be tested
for compatibility in advance