

DALI-2 Phase Cut Sensor

Datasheet Interface

Interface for converting 0-230V
control signals to DALI dim levels



Art. Nr. 86468411

Art. Nr. 86468411-PS

DALI-2 Phase Cut Sensor Interface

Overview

- Compact interface module for the conversion of 0-230V PhaseCut control signals to DALI dim levels
- Version with 30mA DALI power supply for up to 10 standard DALI ballasts, up to 64 ballasts controllable with the help of a DALI-Expander
- The converted value is sent broadcast on the DALI subnet
- A change in the input voltage signal (>1%) is used as trigger event.
- A base load must be provided to use the control unit

Specification, Characteristics

type	DALI-2 PH-Cut Sensor	DALI-2 PH-Cut Sensor PS30
article number	86468411	86468411-PS
Input L,N		
input type	--	supply, mains- voltage
marking terminals	--	L, N
input voltage range	--	210Vac ... 250Vac
input supply frequency	--	50-60Hz
Leistungsaufnahme max.	--	2 Watt
Output DA+,DA-		
output type	DALI control	DALI power supply 30mA DALI control
marking terminals	DA, DA	DA+, DA-
voltage range	9,5Vdc ... 22,5Vdc according to IEC 62386	12,0Vdc ... 20,5Vdc according to IEC62386
guaranteed DALI supply current	---	30mA
max. DALI supply current	---	250mA ¹
typ. current consumption	3mA	--
Input L \approx, N		
input type	control input	
marking terminals	L \approx , N	
input voltage range	0 - 230V	
general data		
dimensions (l x w x h)	60mm x 33mm x 15mm	
mounting	back box installation	
rated max. temperature tc	75°C	
protection class	II (when used/installed as intended)	

¹ No additional DALI bus power supplied can be connected, a DALI bus extension is possible via a [DALI-2 Expander \(ArtNr: 89452937\)](#).

protection degree	IP20
functionality	signal converter

environmental conditions

storing and transportation temperature	-20°C ... +75°C
operational ambient temperature Ta	-20°C ... +60°C
rel. humidity, none condensing	15% ... 90%

terminals

connection type	spring terminal connectors
wire size solid core	0,5 ... 1,5 mm ² (AWG20 ... AWG16)
Wire size stranded wired	0,5 ... 1,5 mm ² (AWG20 ... AWG16)
wire size using wire end ferrule	0,25 ... 1 mm ²
stripping length	8,5 ... 9,5mm / 0,33 ... 0,37inch
release of wire	push button

standards

DALI	EN 62386-101
EMC	EN 61547
	EN 50015 / IEC CISPR15
Safety	EN 61347-2-11
	EN 61347-1
markings	DALI-2, CE, UKCA

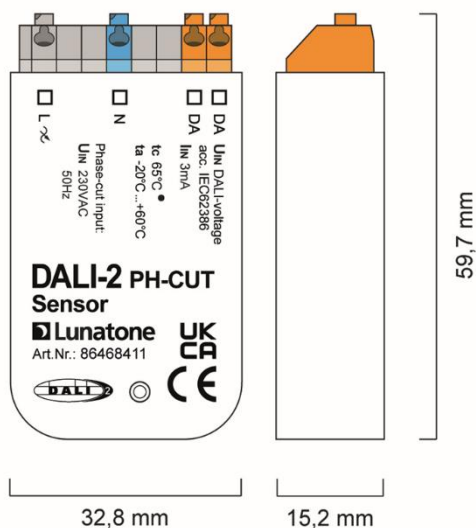

Geometry 86468411

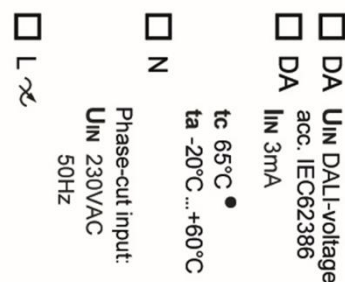

connection plan 86468411

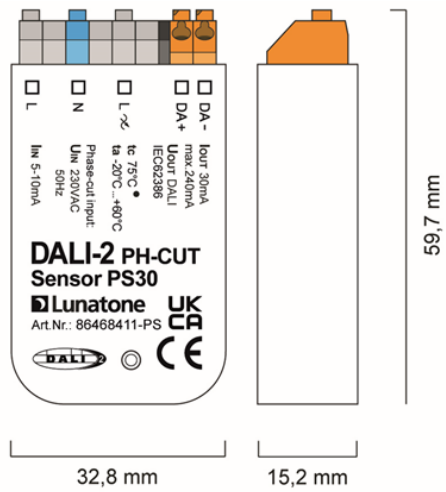

Geometry 86468411-PS

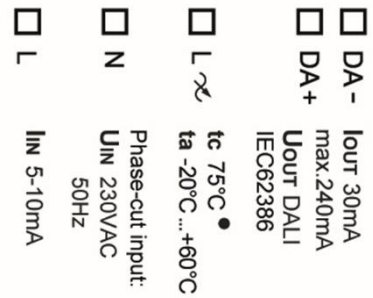

connection plan 86468411-PS

Typical Application

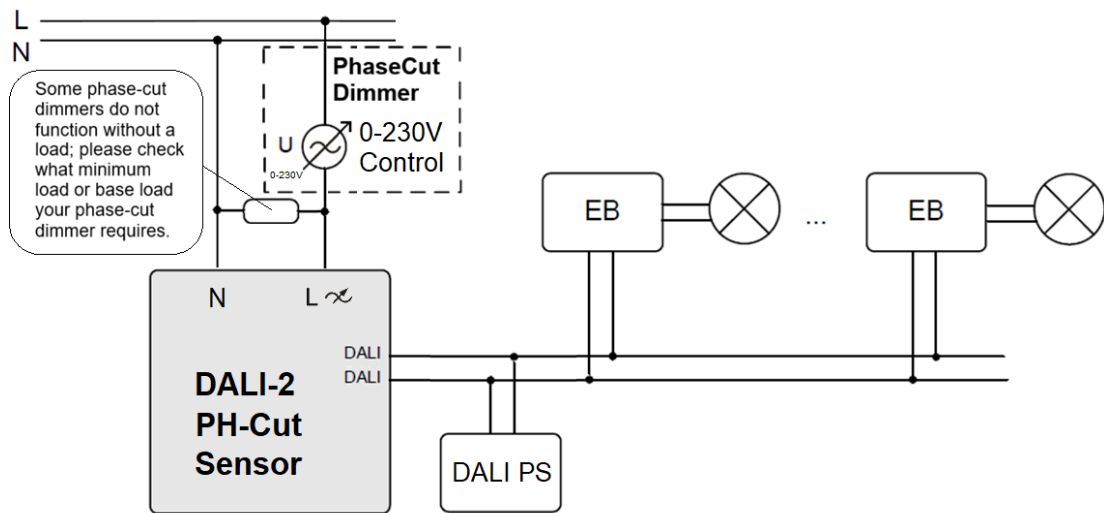

typical application DALI-2 Phase Cut Sensor

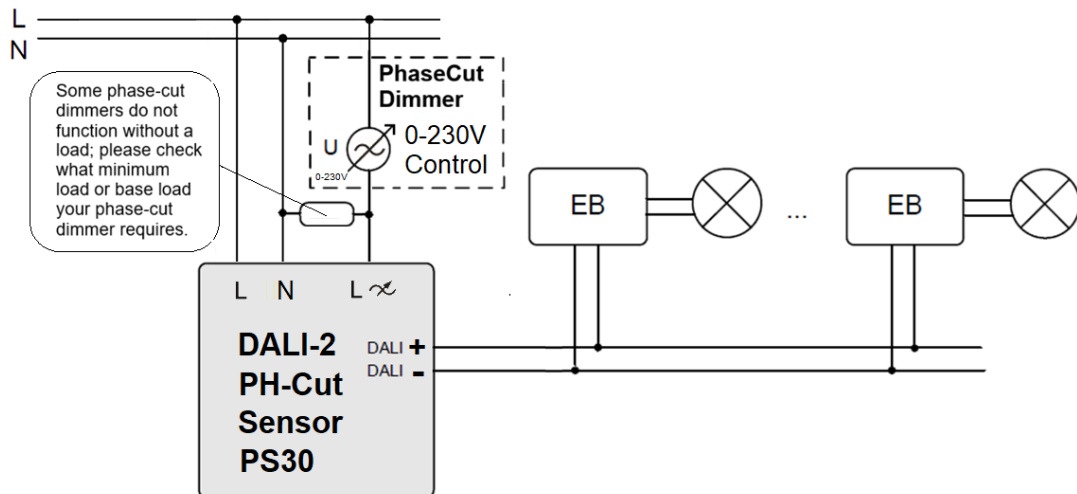

typical application DALI-2 Phase Cut Sensor PS30

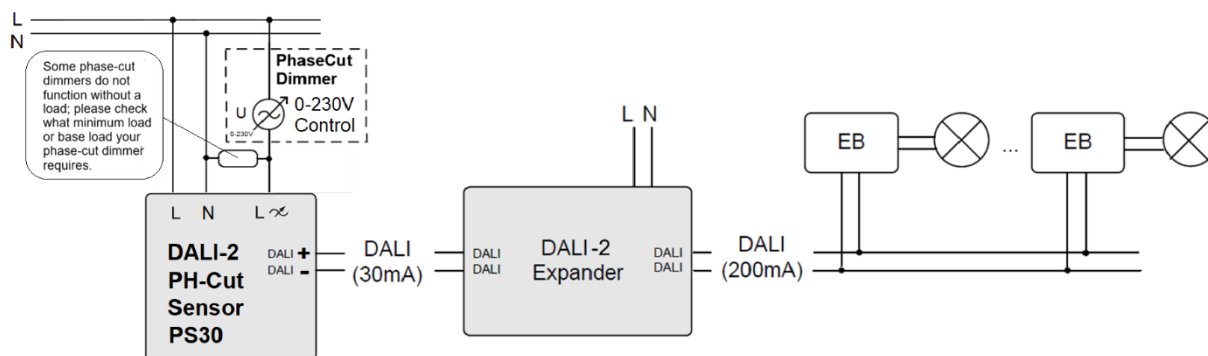

Control of 64 DALI-luminaires with a DALI-2 Phase Cut Sensor PS30 and the help of a [DALI-2 Expander \(ArtNr: 89452937\)](#)

Factory Default Settings

A basic configuration is already implemented on delivery (factory default setting). If necessary, this can be changed and adapted.

Input function	3% - 100% conversion
Low voltage behaviour	OFF below Umin
Effective range	Broadcast
Fade time	0.7sec
Value output	at level change > 1%

Installation

- The device is intended for back box installation or in an enclosure, ensure proper cable relief for installation in protection class II devices.
- The wiring should be carried out as a permanent installation in a dry and clean environment.
- Installation may only be carried out in a voltage-free state of the system and by qualified specialists.
- National regulations for setting up electrical systems must be followed.
- Connect power supply terminals L and N to mains voltage according to the labelling.
- **DALI-2 Phase Cut Sensor PS30:** the polarity of the output voltage is marked on the housing (DA+, DA-)
- **DALI-2 Phase Cut Sensor:** the connection to the DALI terminals can be made regardless of polarity.
- The DALI line may be routed together with the mains voltage (in one cable or as single wires in a tube).
- The DALI-line must **not** be connected to mains or a extra low voltage systems (SELV).
- Only 1 wire may be connected to each terminal. When using double wire end ferrules, the connection capacity of the terminal must be considered.

- The DALI wiring can be realised with standard low-voltage installation material. No special cables are required.
- Wiring topology of the DALI-line: Line, Tree, Star.



Attention: The DALI-signal is not classified as SELV circuit (Safety Extra Low Voltage). Therefore, the installation regulations for low voltage apply.



The voltage drop on the DALI line must not exceed 2V at maximum length (300m) and maximum bus load (250mA).

- Do not use standard DC power supplies on the DALI-line, since they do not meet the requirements for DALI communication.



Attention: an unsuitable DALI power supply can cause damage of the DALI devices!

Commissioning

- After installation, the device can be used with the default factory settings.
- Addressing and changes to the factory settings (e.g. effective range, conversion function), are possible with the Software tool DALI Cockpit (Windows PC).
- When using the [DALI Cockpit Software](#), the PC must be connected to the DALI bus via a suitable interface module ([DALI-2 USB](#); [DALI USB](#), [DALI-2 WLAN](#), [DALI-2 Display](#), [DALI-2 IoT](#), [DALI 4Net](#), [DALI SCI RS232](#)). The device is automatically recognised by the DALI Cockpit during the addressing process and listed in the device overview. Effective range and conversion functions can be configured
- The addressing is done according to the DALI-2 specification and the device receives a corresponding address.
- For localisation a serial number visible in the DALI Cockpit “device info” is attached on the device.

0-230V to DALI conversion

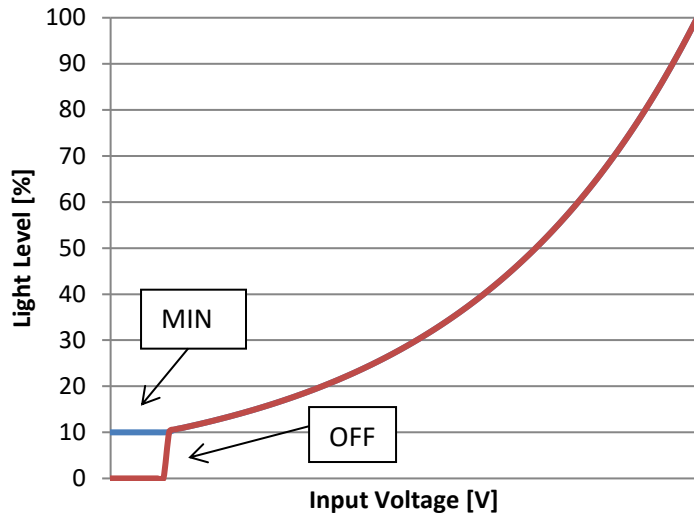

Conversion Curve:

The input voltage range is converted to the light level range of the connected DALI ballast.

The input voltage is converted to either 3%-100% or 10% -100% light level

ON/OFF:

As behaviour below Umin the device can either switch OFF (red) or send the minimum level (blue).

The light level is the output power of a standard DALI-ballast (IEC62386-102) which is connected to the converter.

DALI Cockpit device configuration

Device Info			
Name	PH-Cut DALI-2 PS30	Article Number	86468411-PS
		GTIN	9010342015076
Manufacturer	Lunatone	Serial Number	
		FW	2.1
Device Type	-	Type	Control Device
DALI Ver	V2.0	Short Address	(A0 ²) PH-Cut DALI-2 PS30
			<input type="button" value="Set"/>

General Instances Settings

Destination Address:

Output Function: Low Voltage Behavior: Fade Time

Value output and repetition
 at level change > 1%
 repeat every sec

DALI-2 Instance

When only using DALI-2 instances without an application controller, no DALI control commands are sent on the bus, but DALI-2 event messages for DALI-2 compatible central control systems. General information on DALI-2 Instancemode can be found [here](#).

The DALI-2-Phase Cut Sensor supports one instances of type 2 (IEC62386-301, Analogue Input Device).

The event input value of the analogue instance corresponds to the input value. If this value is changed, the instance generates a DALI-2 event ("INPUT NOTIFICATION").

Parameters of the analogue instance are: event filter and event timer settings (report, deadtime), which can be configured via the DALI Cockpit Software, see Figure below

By using the report timer, the input value is sent periodically as a DALI-2 event regardless of input value changes. (Report Timer set to 0s, means no event is sent)

The deadtime can be used to prevent the generation of an event by the instance for the set deadtime-period.

The screenshot shows the 'Settings' tab of the DALI Cockpit Software configuration interface. The 'Instanznummer [iN]' is set to 0. The 'Instance type [iT]' is set to '2 - Absolute input device'. The 'Enable Event Messages' checkbox is checked. The 'Primary Instance Group [iG]', 'Instance Group 1 [iG]', and 'Instance Group 2 [iG]' are all set to 'None'. The 'Event scheme' is set to 'Instance addressing' and the 'Event priority' is set to 'Priority 3'. Under 'Event Filter', the 'Position' checkbox is checked. Under 'Timers', the 'Report' timer is set to 0 s and the 'Deadtime' timer is set to 0.10 s.

Purchase Information

Art.Nr. 86468411: DALI-2 Phase Cut Sensor, 0-230V to DALI converter, configurable dim characteristic

Art.Nr. 86468411-PS: DALI-2 Phase Cut Sensor PS30, 0-230V to DALI converter, internal 30mA DALI power supply, configurable dim characteristic

Additional Information and Equipment

DALI-Cockpit – DALI system configuration tool, free when using a Lunatone interface device
<https://www.lunatone.com/en/product/dali-cockpit/>

Lunatone DALI products
<http://www.lunatone.at/en/>

Lunatone datasheets and manuals
<http://lunatone.at/en/downloads/>

Contact

Technical Support: support@lunatone.com

Requests: sales@lunatone.com

www.lunatone.com

Disclaimer

Subject to change. Information provided without guarantee.
The datasheet refers to the current delivery.

The compatibility with other devices must be tested in advance to the installation.