

DALI-2 RM8/16/25



Datasheet DT7 Relay Module

Relay Module for the integration of non-dimmable ballasts in DALI lighting systems (DT7)



Rail mounting

RM8 HS	Art.Nr. 86456944-HS
RM16 I HS	Art.Nr. 86456203-I-HS
RM16 IS HS	Art.Nr. 86456203-IS-HS
RM25 HS	Art.Nr. 86457294-HS
RM8 HS WE	Art.Nr. 86456944-HS-WE
RM16 HS WE	Art.Nr. 86456203-HS-WE

Remote ceiling

RM16 DE	Art.Nr. 86456203-DE
RM25 DE	Art.Nr. 86457294-DE

Back box

RM5	Art.Nr. 86456114
RM8	Art.Nr. 86456944
RM8-WE	Art.Nr. 86456944-WE
RM16	Art. Nr. 86456753



Datenblatt Deutsch: https://www.lunatone.com/wp-content/uploads/2024/06/86456944_86456203_DALI-2_RM8_RM16_RM25_GER_D0130.pdf

DALI-2 RM 8/16/25 DT7 Relay Module

Overview

- Compact relay module for the direct control of 230V AC loads via DALI
- Ballasts without DALI-input can be simply integrated in a DALI lighting control system. The loads can then be switched ON and OFF by DALI commands.
- The DALI-2 RM8/16/25 module fulfils the requirements for DALI Device Type 7 - switching function
- Configurable Power-Up and System-Failure behaviour
- Easy configuration via Lunatone DALI USB interface and DALI-Cockpit Software Tool (suitable interface modules: [DALI-2 USB](#); [DALI USB](#), [DALI-2 WLAN](#), [DALI-2 Display](#), [DALI-2 IoT](#), [DALI 4Net](#), [DALI SCI RS232](#)). The RM8 is supplied directly by the DALI signal line
- The DALI-2 RM 8/16 is supplied directly by the DALI signal line, no additional power supply necessary
- Zero cross switching
- RM16-I-HS and RM16-IS-HS: inrush currents up to 350A
- Standby Feature
- RM16 IS HS: lever on device to manually control relay.
- Time switch functionality
- The modules act like any conventional DALI ballast, and can be addressed and configured accordingly.



Specification, Characteristics

DIN Rail models

type	DALI-2 RM8 HS	DALI-2 RM16 I HS	DALI-2 RM25 HS	DALI-2 RM8 HS WE	DALI-2 RM16 HS WE
article number	86456944-HS	86456203-I-HS 86456203-IS-HS	86457294-HS	86456944-HS-WE	86456203-HS-WE

electrical data					
supply	via DALI-line				
current consumption (at 16.5V)	3.8 mA				
relay output switch on/off voltage (resistive)	250Vac		270Vac	250Vac	
max. nominal load circuit breaker	1000VA 6A max	3000VA 16A max	4000VA 20A max	1000VA 6A max	2000VA 12A max
max. breaking current	8A	20A	40A	8A	16A
max. inrush current	40A	320A	1000A	40A	80A
max. continuous current	8A	16A	25A	8A	8A
switching method	zero cross switching				
type of relay contact	normally open	normally open	normally open	change-over	change-over

type	DALI-2 RM8 HS	DALI-2 RM16 I HS	DALI-2 RM25 HS	DALI-2 RM8 HS WE	DALI-2 RM16 HS WE
article number	86456944-HS	86456203-I-HS 86456203-IS-HS	86457294-HS	86456944-HS-WE	86456203-HS-WE
switching operations at nominal load, resistive	>10 ⁵	>10 ⁵	>10 ⁵	>10 ⁵	>3x10 ⁴
maximum switching frequency	1Hz				
input	DALI				
number of used DALI addresses	1				
start up time	550ms				

general data

dimensions	98mm x 17.5mm x 56mm
mounting	DIN rail
protection class	II in intended use
protection degree	IP20
behaviour at Power Up	programmable: ON/OFF/no Change
behaviour at System failure	programmable: ON/OFF/no Change

environmental conditions

storage and transportation temperature	-20°C ... 75°C
operating ambient temperature	-20°C ... 60°C

terminals relay



connection type	screw connector		
wire size: solid core	0.5 ... 2.5 mm ² (AWG20 ... AWG14)	1 ... 6 mm ² (AWG30 ... AWG10)	0.5 ... 2.5 mm ² (AWG20 ... AWG14)
wire size: fine wired	0.5 ... 2.5 mm ² (AWG20 ...AWG14)	1 ... 6 mm ² (AWG30 ...AWG10)	0.5 ... 2.5 mm ² (AWG20 ...AWG14)
wire size: using wire end ferrule	0.25 ... 1.5 mm ²	-	0.25 ... 1.5 mm ²
stripping length	7 mm / 0.27 inch		
tightening/ release of wire	0.5Nm		
release of wire	open screw		

Terminals DALI



connection type	screw connector
wire size: solid core	0.5 ... 2.5 mm ² (AWG20 ... AWG14)
wire size: fine wired	0.5 ... 2.5 mm ² (AWG20 ...AWG14)
wire size: using wire end ferrule	0.25 ... 1.5 mm ²
stripping length	7 mm / 0.27 inch
tightening/ release of wire	0.5Nm
release of wire	open screw

standards	
DALI	IEC 62386-102 IEC 62386-208
EMC	EN 61547 EN 50015 / IEC CISPR15
safety	EN 61347-2-11 EN 61347-1
markings	DALI-2, CE, UKCA

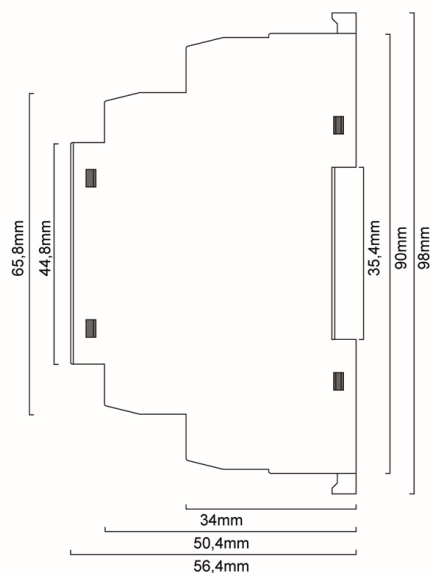

dimensions RM8 HS



17,5mm

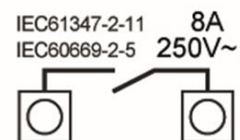

connection plan RM8 HS

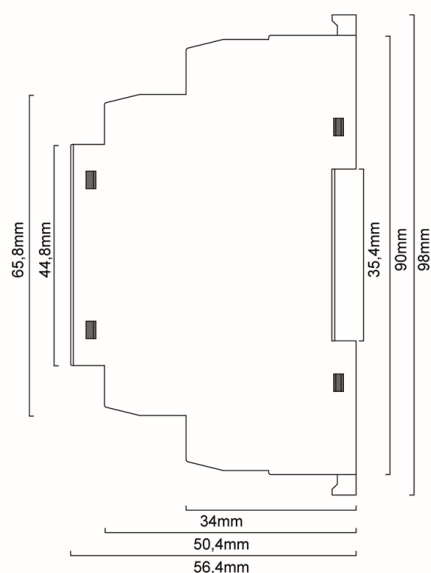

dimensions RM16 HS



17,5mm

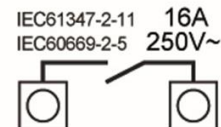

connection plan RM16 HS

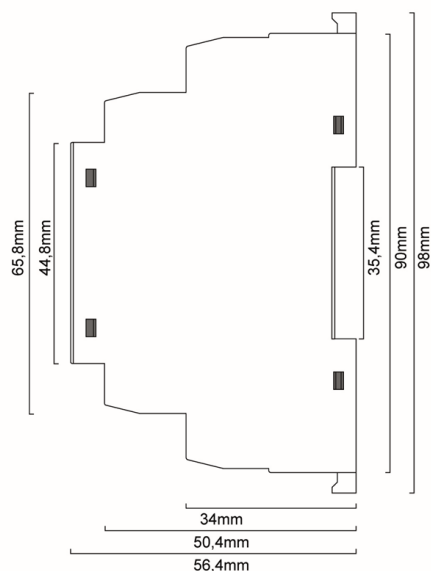

dimensions RM16 HS WE

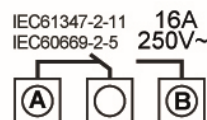

connection plan RM16 HS WE

Remote ceiling models

type	DALI-2 RM16 DE	DALI-2 RM25 DE
article number	86456203-DE	86457294-DE

electrical data

supply	via DALI-line	
current consumption (at 16.5V)	3.8 mA	
relay output switch on/off voltage	277Vac	
max. nominal load	3000VA	5000VA
circuit breaker	16A max	25A max
max. breaking current	20A	40A
max. inrush current	350A	1000A
max. continuous current	16A	24A
switching method	zero cross switching	
type of relay contact	1 normally open	
switching operations at nominal load, resistive	>10 ⁵	
maximum switching frequency	1Hz	
Input	DALI	
number of used DALI addresses	1	
start up time	590ms	

general data

dimensions	120mm x 30mm x 22mm
mounting	remote ceiling
protection class	II in intended use
protection degree	IP20
behaviour at Power Up	programmable: ON/OFF/no Change
behaviour at System failure	programmable: ON/OFF/no Change

environmental conditions

storage and transportation temperature	-20°C ... 75°C
operating ambient temperature	-20°C ... 60°C

terminals relay 

connection type	spring terminal connector (cage clamp)
wire size: solid core	0.08 ... 2.5 mm ² (AWG28 ... AWG14)
wire size: fine wired	0.08 ... 2.5mm ² (AWG 28 ... AWG 14)
wire size: using wire end ferrule	0.25 ... 1.5 mm ²
stripping length	5 ... 6 mm / 0.2 ... 0.24 inch
tightening/ release of wire	push back spring with tool

Terminals DALI 

connection type	spring terminal connectors (push in cage clamp)
wire size: solid core	0.5 ... 1.5 mm ² (AWG20 ... AWG16)
wire size: fine wired	0.5 ... 1.5 mm ² (AWG20 ...AWG16)
wire size: using wire end ferrule	0.25 ... 1 mm ²
stripping length	8.5 ... 9.5 mm / 0.33 ... 0.37 inch
tightening/ release of wire	push mechanism

standards

DALI	IEC 62386-102, IEC 62386-208
EMC	EN 61547, EN 50015 / IEC CISPR15
safety	EN 61347-2-11, EN 61347-1
markings	DALI-2, CE, UKCA

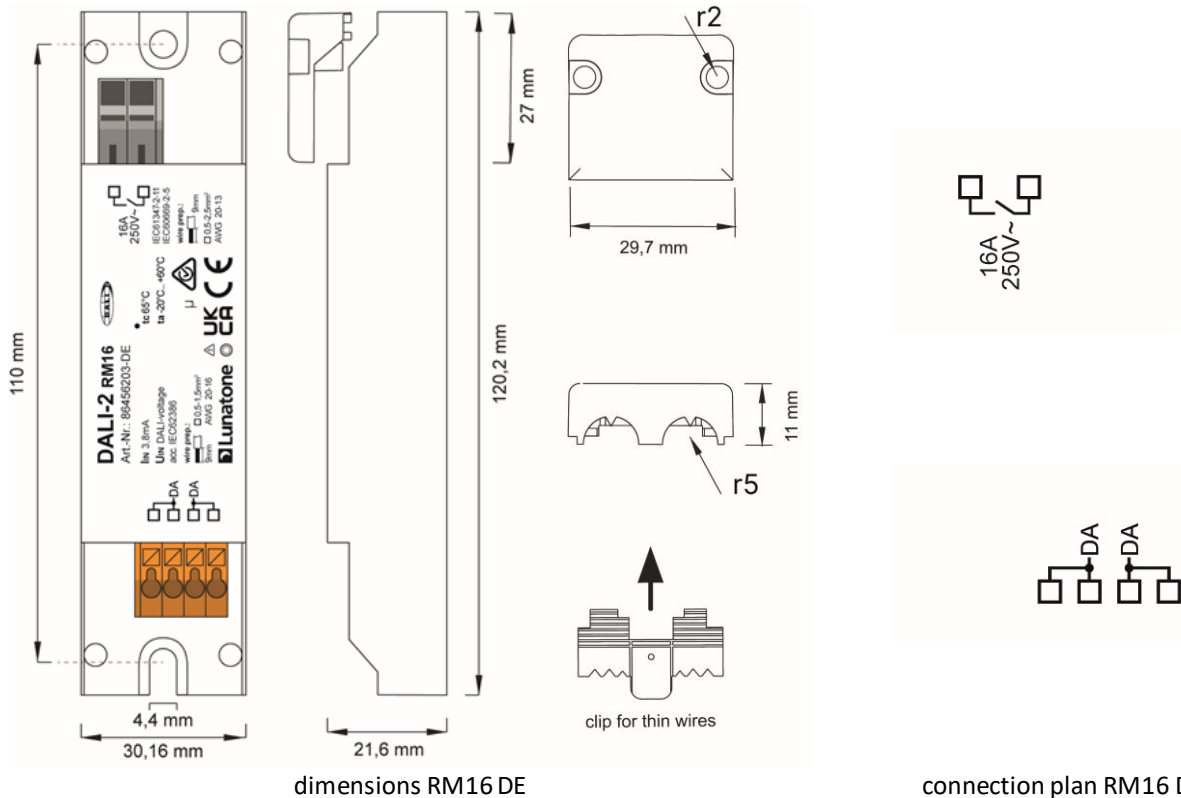

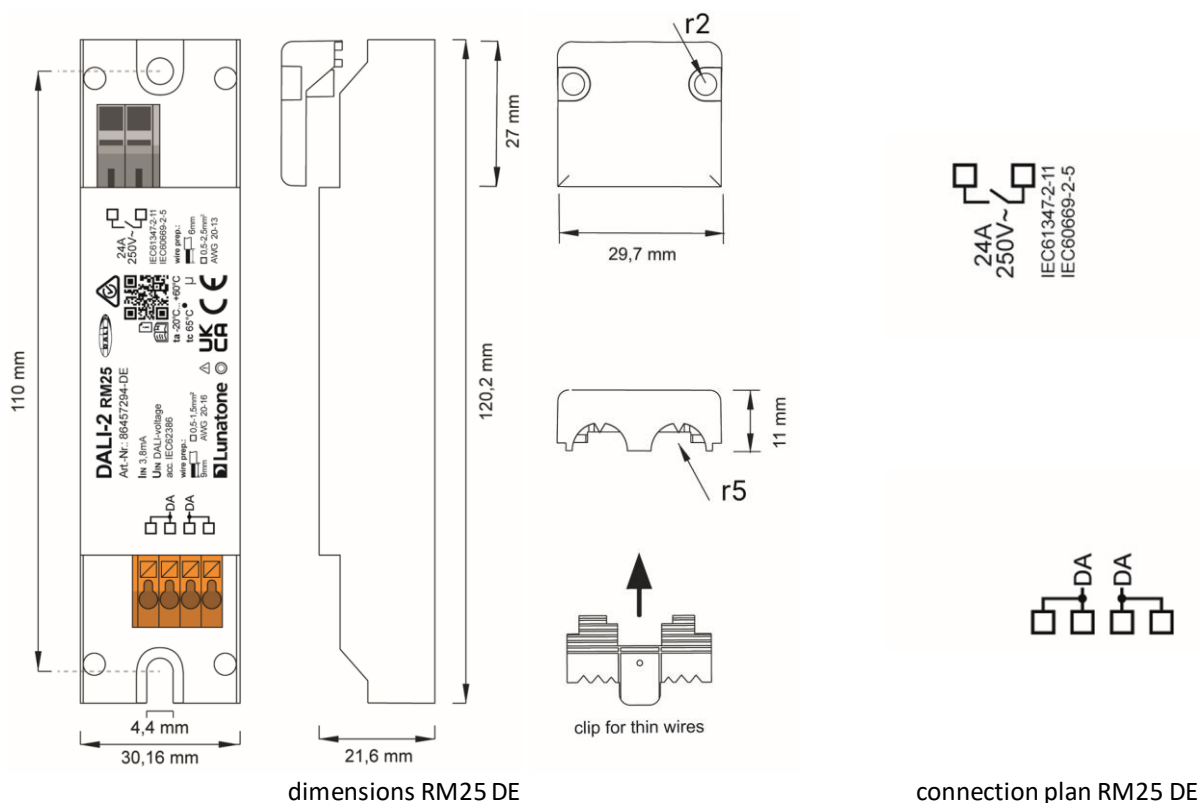

dimensions RM25 DE

connection plan RM25 DE

Installation box models

type	DALI-2 RM5	DALI-2 RM8	DALI-2 RM8 WE	DALI-2 RM16
article number	86456114	86456944	86456944-WE	86456753

electrical data:

supply	via DALI-line			
current consumption (at 16.5V)	3.8 mA			
relay output switch on/off voltage	277Vac			
max. nominal load	1000VA	1500VA	1000VA	3000VA
circuit breaker	6A max	16A max	6A max	16A max
max. breaking current	12A	20A	12A	20A
max. inrush current	60A	350A	60A	350A
max. continuous current	5A	8A	8A	2x8A
switching method	zero cross switching			
type of relay contact	1 normally open	1 normally open	1 changeover	1 normally open
switching operations at nominal load, resistive	>10 ⁵	>10 ⁵	>10 ⁵	>10 ⁵
maximum switching frequency	1Hz			
input	DALI			
number of used DALI addresses	1			

general data

dimensions	59mm x 33mm x 15mm
mounting	installation box
protection class	II in intended use
protection degree	IP20
behaviour at Power Up	programmable: ON/OFF/no Change
behaviour at System failure	programmable: ON/OFF/no Change

environmental conditions

storage and transportation temperature	-20°C ... 75°C
operating ambient temperature	-20°C ... 60°C

terminals

connection type	spring terminal connectors
wire size: solid core	0.5 ... 1.5 mm ² (AWG20 ... AWG16)
wire size: fine wired	0.5 ... 1.5 mm ² (AWG20 ...AWG16)
wire size: using wire end ferrule	0.25 ... 1 mm ²
stripping length	8.5 ... 9.5 mm / 0.33 ... 0.37 inch
tightening/ release of wire	push mechanism

standards

DALI	IEC 62386-102, IEC 62386-208
EMC	EN 61547, EN 50015 / IEC CISPR15
safety	EN 61347-2-11, EN 61347-1
markings	DALI-2, CE, UKCA

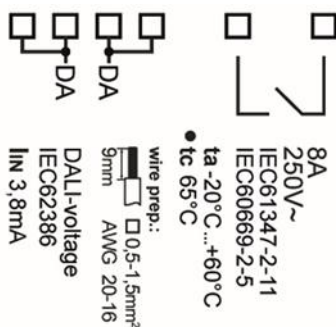
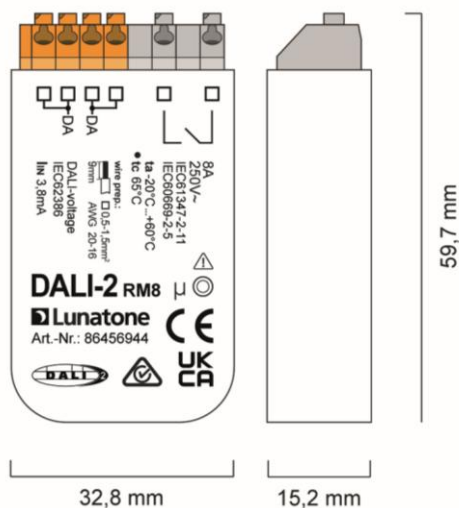
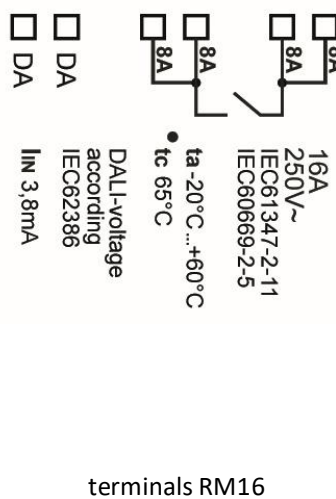
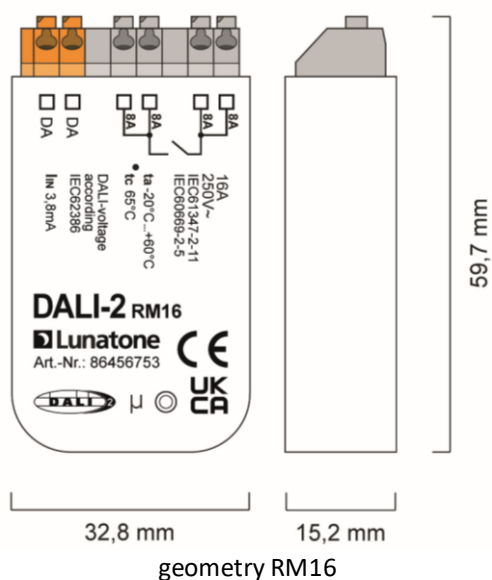

geometry RM8

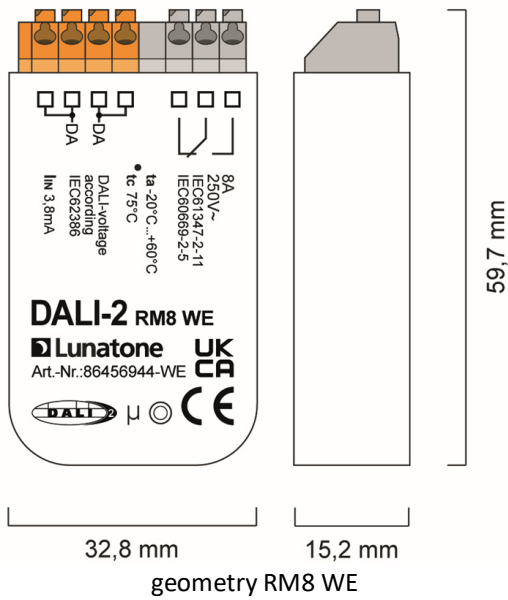

terminals RM8

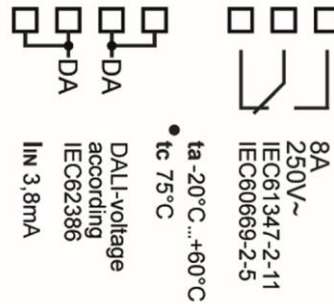

geometry RM8 WE

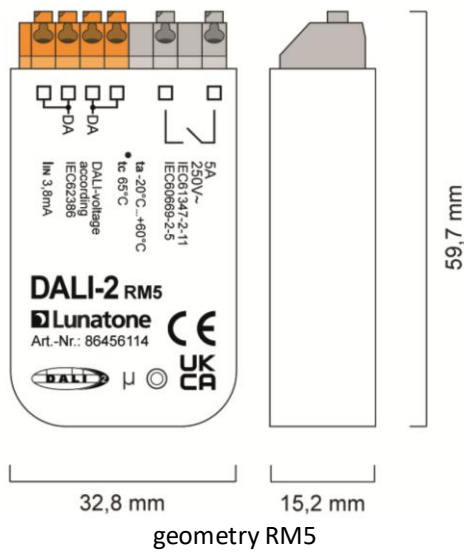

terminals RM8 WE

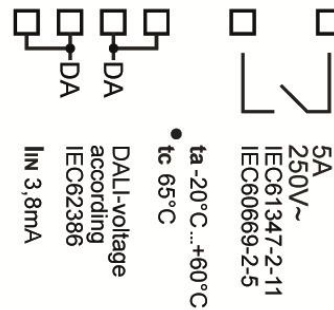

geometry RM5

terminals RM5

Typical Application

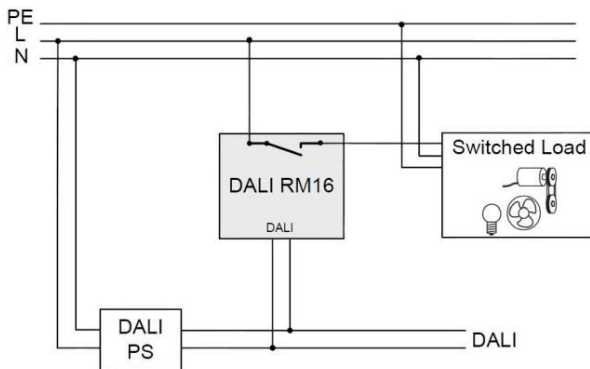

Hint: In order to ensure that the load current does not exceed the maximum switching current, the installation must be secured with a suitable automatic circuit breaker.

Factory Default Settings

A basic configuration is already implemented on delivery (factory default setting). If necessary, this can be changed and adapted.

	Factory default	DALI Standard
Min Level	0.1%	100%
Max Level	100%	100%
Power On Level	100%	100%
System Failure Level	MASK (last value)	100%
Fade Time	none	none
Fade Rate	44.7 steps/s	44.7 steps/s
Scene values	all scenes: MASK	all scenes: MASK
Behaviour at DALI RESET command	set DALI Standard values, see column 2	N/A (remains unchanged)
Ignore broadcast commands	disabled	N/A (remains unchanged)
Dim UP switch ON threshold	0.103% (DAP 2)	0.1% (DAP 1)
Dim UP switch OFF threshold	MASK	MASK
Dim DOWN switch ON threshold	MASK	MASK
Dim DOWN switch OFF threshold	0.1% (DAP 1)	0% (DAP 0)
Power up switching delay	0 s	N/A (remains unchanged)
Line frequency (zero-crossing detect.)	50 Hz	N/A (remains unchanged)
Standby feature	disabled	N/A (remains unchanged)

Installation

- The DALI-2 RM8/RM16/RM25 is directly connected and supplied by the DALI bus. A DALI bus power supply (e.g. [DALI PS](#)) is required, an additional power supply is not necessary.
- The connection to the DALI terminals can be made regardless of polarity. The bus input is protected against overvoltage (mains voltage up to 250VAC).
- The DALI-line must **not** be connected to the mains or extra low voltage systems.
- The device versions for installation-box and remote ceiling have double DALI terminals to allow simple looping through of the DALI bus (which DALI-terminals are internally connected is visualized on the housing, see also the connection plan).
- The relay output of the RM8/16/25 supports loads up to 3000VA and switching currents up to 16A (type dependent, check specification for details).
- In order to ensure that the load current does not exceed the maximum switching current of the relay a suitable automatic circuit breaker has to be installed.
- Switching is done at zero cross of ac voltage.
- The wiring should be carried out as a permanent installation in a dry and clean environment.
- **Remote Ceiling and Electrical Box Versions:** Installation may only be carried out in a voltage-free state of the system and by qualified specialists.
- **DIN Rail Versions:** Installation may only be carried out in a voltage-free state of the system and by qualified specialists, in control cabinets that comply with the EN 61439 standard.
- National regulations for setting up electrical systems must be followed.
- The DALI wiring can be realised with standard low-voltage installation material. No special cables are required.

- Wiring topology of the DALI-line: Line, Tree, Star
- Only 1 wire may be connected to each terminal. When using double wire end ferrules, the connection capacity of the terminal must be considered.



Attention: The DALI-signal is not classified as SELV circuit (Safety Extra Low Voltage). Therefore, the installation regulations for low voltage apply



The voltage drop on the DALI line must not exceed 2V at maximum length (300m) and maximum bus load (250mA).

Addressing and Configuration

- After installation the DALI-2 RM8/16/25 is ready for use
- The configuration can be done with the help of the [DALI Cockpit Software](#). The PC must be connected to the DALI bus via a suitable interface module ([DALI-2 USB](#); [DALI USB](#), [DALI-2 WLAN](#), [DALI-2 Display](#), [DALI-2 IoT](#), [DALI 4Net](#), [DALI SCI RS232](#)).
- The DALI-2 RM8/16/25 is automatically recognised by the DALI Cockpit during the addressing process and listed in the device overview.
- The standard DALI device settings as well as the device specific settings can be configured in the DALI Cockpit, see section "Functionality".
- The "Identify" function can be used for localization after addressing. With the DALI command IDENTIFY, or selecting the checkbox "localise" in the DALI Cockpit the relay switches.
 - localise

The IDENTIFY command should not be used if switching of the relay is not desired. Alternatively, the allocation can also be done via the serial number of the device.

Functionality

The DALI RM 8/16 acts as a DALI-controlled relay contact. Hence ballasts can be integrated in a DALI-system and switched on and off by DALI commands.

The DALI-2 RM8/16/25 acts like a standard DALI ballast for non-dimmable loads. It is based on the DALI specification for control gear (IEC 62386-102) and the device type 7 extension (IEC 62386-208). Therefore, the switching characteristic is determined by the comparison of the virtual direct arc power level (VDAP) with 4 thresholds.

The virtual dim level (VDAP) is like the dim level of DALI-ballasts and is therefore limited by MINLEVEL and MAXLEVEL and influenced by fade-time and fade-rate.

For each dim direction 2 thresholds can be defined. They are compared with the virtual dim level and as a result the output is switched on or off:

virtual dim direction	comparison of virtual dim level and thresholds	output
UP	VDAP >= UP SwitchOn Threshold	ON
UP	VDAP >= UP SwitchOff Threshold	OFF
DOWN	VDAP <= DOWN SwitchOn Threshold	ON
DOWN	VDAP <= DOWN SwitchOff Threshold	OFF

If a threshold value is set to "MASK" the threshold is inactive and does not influence the relay output.

Some examples of switching characteristics below:

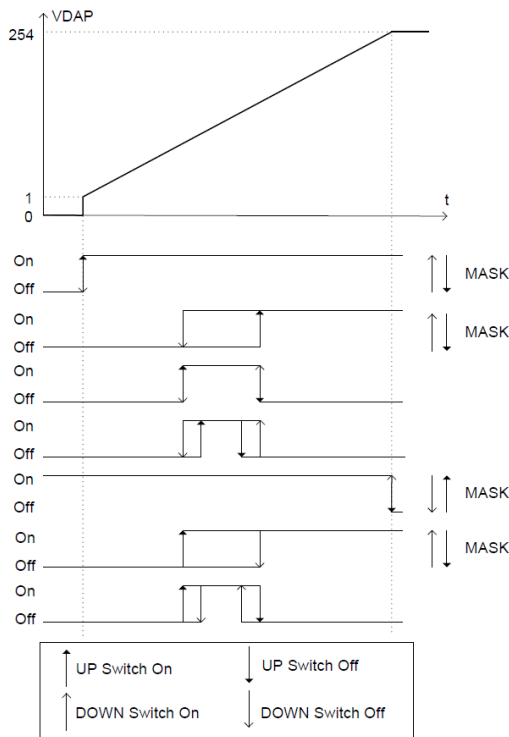

With the help of the fade time switch on and switch off delays can be realized.

Adjustable RESET behaviour

The response to a DALI reset command is configurable. The following options are available:

- *Ignore command:* the DALI reset command does not trigger any changes to the device settings
- *DALI standard:* the selected device settings are reset to the values defined in the DALI standard (see table 1 below - second column: DALI standard values)
- *Custom settings:* the current device settings can be saved. With a DALI Reset command, the selected parameters (6 check boxes) are then reset to these saved values.

Behavior on DALI Reset Command

Parameters are reset to DALI Standard values. Change...

Power-ON and System-Failure behaviour

The DALI-2 RM8/16/25 is bus-powered. The reaction on a system failure can be configured (keep relay state, on or off, factory default: keep state (MASK)). Similarly the Power On level can be configured which is applied in case of switching on the DALI-line supply voltage. Additionally a switching delay can be configured between 0 and 10 seconds after power-up.

Power Up Behavior

Switching Delay: [0..10 sec]

Ignore Broadcast Commands

The broadcast control can be deactivated. Through selection of "Ignore Broadcast", the RM8/16/25 does no longer respond to broadcast commands on the DALI bus (group assignments are not ignored).

Ignore Broadcast Config and Arc commands i

Ignore Broadcast commands

Time switch functionality

Timed switching can be activated for four selectable scenes; an immediate action (0%/100%/none) and a delayed action (0%/100%) can be configured. The delay can be selected from 1s-3h.

Important: to use the time switch functionality for a scene the entry has to be activated with the checkbox "enable"!

Delayed Switching i

En	↓	↑	del.	Command	Time[...]
•	↑	↓		GOTO SCENE 0	00:03:00
•	↑	↓		GOTO SCENE 1	00:10:00
•	↑	↓		GOTO SCENE 2	00:00:10
•	↑	↓		GOTO SCENE 3	01:00:00

Enable

DALI Command: GOTO SCENE 3

Switching

immediate: 0% 100% No Change

after delay: 0% 100%

delay: 1 H. 0 Min. 0 Sec.

Standby Functionality

Enable Standby feature

In order to reduce the standby energy consumption of DALI operating devices, the power supply for these devices can be switched via the DALI-2 RM16.

This “standby functionality” achieves seamless control of the DALI operating devices. “On” commands (Max/Min/Light Level (DAP)/Last Active/Scenes) sent to groups or broadcast switch on the relay (and thus the power supply to the operating devices). To account for the start time of the operating device, the

command is sent with several repetitions by the RM16 to the operating devices.

Line frequency

Selecting either 50Hz or 60Hz enables correct switching at the zero crossing for the respective frequency. If option “DC” is selected, the device does not wait for a zero crossing.

Line frequency

DC

50Hz

60Hz

Figure 1 DALI Cockpit tab: device parameters

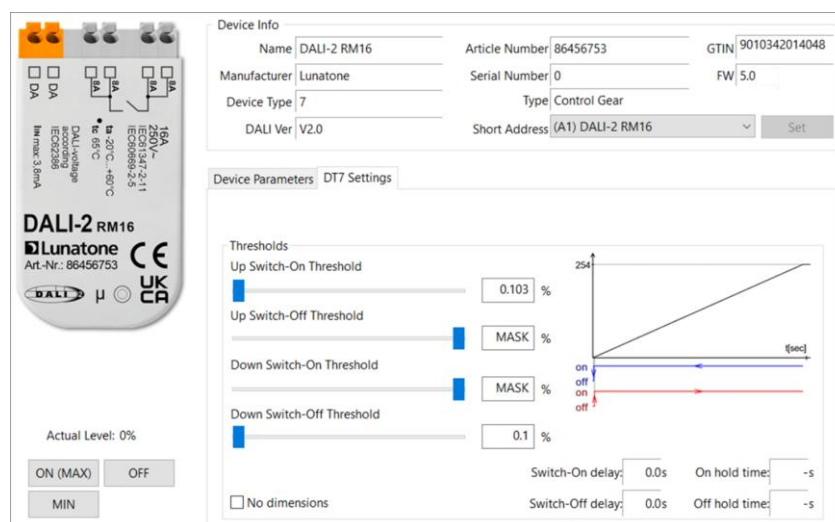

Figure 2 DALI Cockpit tab: DT7 settings

Purchase Information

DIN rail

Art.Nr. 86456944-HS: DALI-2 RM8 HS, 1000VA/8A, zero cross switching, 1 normal open, DIN rail mounting

Art.Nr. 86456203-I-HS: DALI-2 RM16 I HS, 3000VA/16A, zero cross switching, integrated current limiter, 1 normal open, DIN rail mounting

Art.Nr. 86456203-IS-HS: DALI-2 RM16 IS HS, 3000VA/16A, zero cross switching, integrated current limiter, 1 normal open, lever on device, DIN rail mounting

Art.Nr. 86457294-HS: DALI-2 RM25 HS, 4000VA/25A, zero cross switching, integrated current limiter, 1 normal open, DIN rail mounting

Art.Nr. 86456944-HS-WE: DALI-2 RM8 HS WE, 1000VA/8A, zero cross switching, 1 changeover, DIN rail mounting

Art.Nr. 86456203-HS-WE: DALI-2 RM16 HS WE, 2000VA/8A, zero cross switching, 1 changeover, DIN rail mounting

Remote ceiling

Art. Nr. 86456203-DE: DALI-2 RM16 DE, 3000VA/16A, zero cross switching, 1 normal open, remote ceiling

Art. Nr. 86457294-DE: DALI-2 RM25 DE, 4000VA/24A, zero cross switching, 1 normal open, remote ceiling

Installation box

Art. Nr. 86456753: DALI-2 RM16, 3000VA/16A, zero cross switching, 1 normal open, back box

Art. Nr. 86456944: DALI-2 RM8, 1000VA/8A, zero cross switching, 1 normal open, back box

Art. Nr. 86456944-WE: DALI-2 RM8, 1000VA/8A, zero cross switching, 1 changeover, back box

Art. Nr. 86456114: DALI-2 RM5, 1000VA/8A, zero cross switching, 1 normal open, back box

Additional Information and Equipment

DALI-Cockpit – DALI system configuration tool, free when using a Lunatone interface device
<https://www.lunatone.com/en/product/dali-cockpit/>

Lunatone DALI products
<https://www.lunatone.com/en>

Lunatone datasheets and manuals
<https://www.lunatone.com/en/downloads-a-z/>

Contact

Technical Support: support@lunatone.com

Requests: sales@lunatone.com

www.lunatone.com



Disclaimer

Subject to change. Information provided without guarantee.
The datasheet refers to the current delivery.

The compatibility with other devices must be tested in advance to the installation.